



**BioMedical Admissions Test**

**4500/12**

**2022**

**30 minutes**

**SECTION 2**

**Scientific Knowledge and Applications**

**INSTRUCTIONS TO CANDIDATES**

**Please read this page carefully, but do not open the question paper until you are told that you may do so.**

This paper is Section 2 of 3. Your supervisor will collect this question paper and answer sheet before giving out Section 3.

A separate answer sheet is provided for this section. Please check you have one. You also require a soft pencil and an eraser.

Please complete the answer sheet with your:

- BMAT candidate number
- Centre number
- Date of birth
- Name

Speed as well as accuracy is important in this section. **Work quickly, or you might not finish the paper.** There are no penalties for incorrect responses, only marks for correct answers, so you should attempt **all 27** questions. Each question is worth one mark.

Answer on the sheet provided. Questions ask you to show your choice between options by shading one circle. If you make a mistake, erase thoroughly and try again.

You **must** complete the answer sheet within the time limit.

You can use the question paper for rough working or notes, but **no extra paper** is allowed. Only your responses on the answer sheet will be marked.

Calculators are NOT permitted.

**Please wait to be told you may begin before turning this page.**

*This question paper consists of 21 printed pages and 3 blank pages.*



**BLANK PAGE**

**1** Which of the following processes release water vapour into the atmosphere?

**1** combustion of trees

**2** excretion

**3** transpiration

**A** none of them

**B** 1 only

**C** 2 only

**D** 3 only

**E** 1 and 2 only

**F** 1 and 3 only

**G** 2 and 3 only

**H** 1, 2 and 3

2 Apparatus is set up as represented in the diagram.

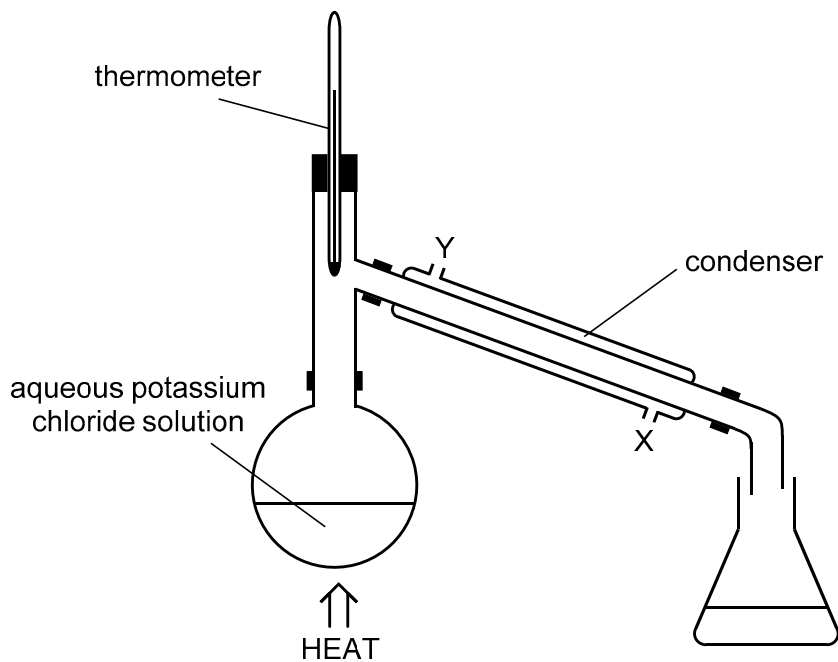

Which of the following statements is/are correct about the use of this apparatus?

- 1 Water for cooling should enter the condenser at X and exit at Y.
- 2 When the mixture in the flask is boiling, the thermometer reading will be at the boiling point of the most volatile component of the mixture in the flask.
- 3 This apparatus is typically used for fractional distillation.

- A** none of them
- B** 1 only
- C** 2 only
- D** 3 only
- E** 1 and 2 only
- F** 1 and 3 only
- G** 2 and 3 only
- H** 1, 2 and 3

- 3 A student carries out an experiment in order to plot the  $V-I$  graph for a filament lamp. The student sets up a circuit using a dc supply. The supply voltage is not known.

Which circuit allows the student to collect this data?

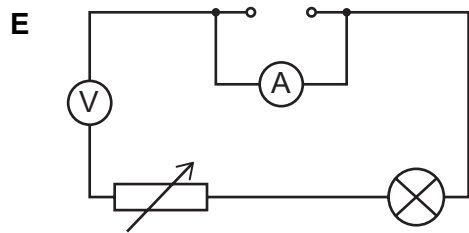
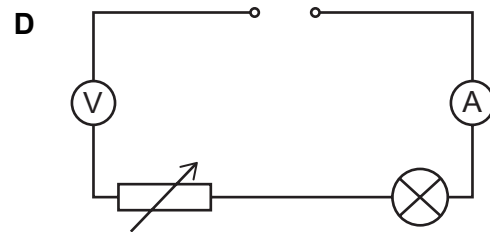
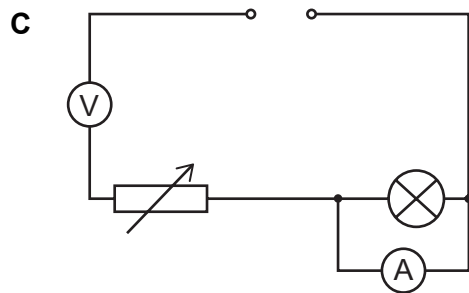
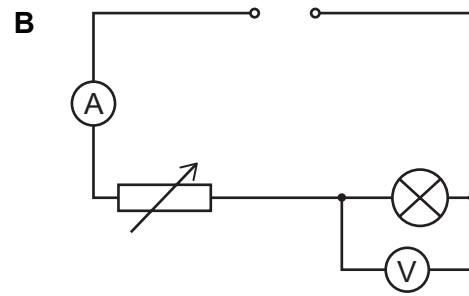
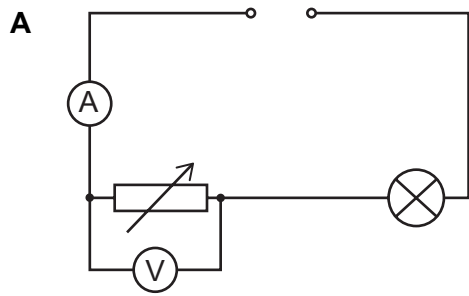

4 Make  $x$  the subject of  $y = x - (2y - (3x - 4y))$

**A**  $x = -\frac{2y}{7}$

**B**  $x = -\frac{2y}{3}$

**C**  $x = -\frac{3y}{2}$

**D**  $x = -\frac{7y}{2}$

**E**  $x = \frac{2y}{3}$

**F**  $x = \frac{3y}{2}$

**G**  $x = \frac{4y}{7}$

**H**  $x = \frac{7y}{4}$

5 The diagram shows a section of DNA.

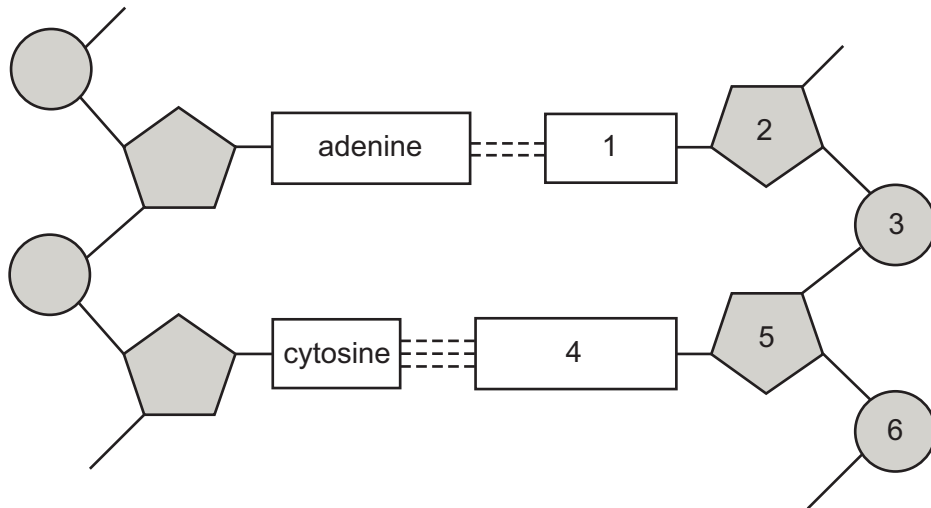

Which row correctly identifies a thymine and a single complete nucleotide?

	<i>a thymine</i>	<i>a single complete nucleotide</i>
<b>A</b>	1	2 and 3
<b>B</b>	4	2 and 3
<b>C</b>	1	4 and 5
<b>D</b>	4	4 and 5
<b>E</b>	1	2, 3 and 5
<b>F</b>	4	2, 3 and 5
<b>G</b>	1	4, 5 and 6
<b>H</b>	4	4, 5 and 6

6 Consider the following particles:

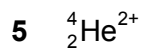
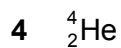
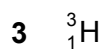
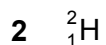
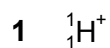

Which of the particles have an equal number of neutrons?

- A none of them
- B 1 and 5 only
- C 2 and 3 only
- D 3 and 4 only
- E 4 and 5 only
- F 1, 2 and 3 only
- G 3, 4 and 5 only

7 An unstable nucleus undergoes a series of radioactive decays by emission of alpha and/or beta ( $\beta^-$ ) particles.

Which of the following complete series of emissions results in a final isotope of the same element as the original nucleus?

- A 1 alpha particle and 1 beta particle
- B 1 alpha particle and 4 beta particles
- C 2 alpha particles and 1 beta particle
- D 2 alpha particles and 4 beta particles
- E 2 beta particles



8 In December, the price of a television in a shop was  $\text{£}P$ .

At the start of January, the price was reduced by  $\text{£}350$ .

At the start of February, the price was further reduced by 30% of the January price.

After the two reductions, the overall decrease in the price of the television was 44%.

What was  $P$ ?

A 625

B 750

C 1540

D 1750

E 2100

F 2500

- 9 In a particular family cystic fibrosis is caused by the inheritance of two recessive alleles of a gene.

In their family tree, only individuals 4 and 11 have the condition. Individual 3 has a homozygous genotype.

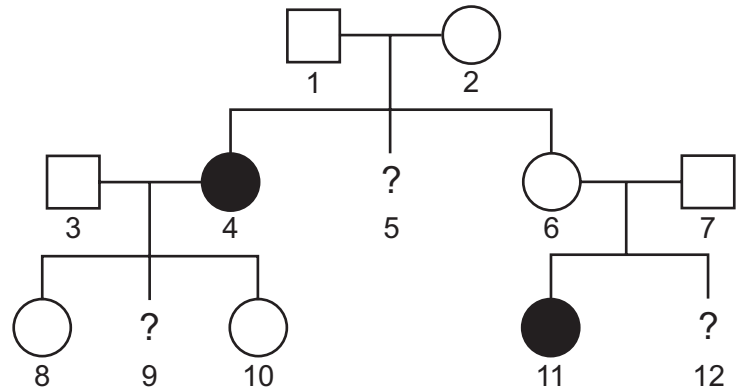
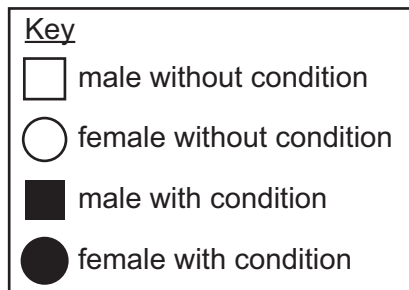

What are the probabilities of individuals 5, 9 and 12 being carriers?

(Assume no new mutations occur.)

	<i>individual 5</i>	<i>individual 9</i>	<i>individual 12</i>
<b>A</b>	25%	50%	25%
<b>B</b>	50%	25%	100%
<b>C</b>	50%	100%	50%
<b>D</b>	100%	50%	50%
<b>E</b>	100%	100%	100%

- 10 Which of the following is a balanced equation for an incomplete combustion of octane ( $C_8H_{18}$ )?

- A**  $C_8H_{18} + 8O_2 \rightarrow 8CO + 8H_2O + H_2$
- B**  $C_8H_{18} + 11O_2 \rightarrow 5CO_2 + 3CO + 9H_2O$
- C**  $C_8H_{18} + 13O_2 \rightarrow 4CO_2 + 4CO + 9H_2O$
- D**  $2C_8H_{18} + 12O_2 \rightarrow CO_2 + 4CO + 2C + 18H_2O$
- E**  $2C_8H_{18} + 25O_2 \rightarrow 16CO_2 + 18H_2O$

- 11** A fixed mass of an ideal gas is at a pressure of 2.0 MPa and occupies a volume of  $2.4 \text{ m}^3$ .  
The pressure is increased by 1.0 MPa, without changing the temperature.  
What is the change in the volume occupied by the gas?
- A** a decrease of  $0.8 \text{ m}^3$
  - B** a decrease of  $1.0 \text{ m}^3$
  - C** a decrease of  $1.2 \text{ m}^3$
  - D** a decrease of  $1.6 \text{ m}^3$
  - E** an increase of  $1.0 \text{ m}^3$
  - F** an increase of  $1.2 \text{ m}^3$
  - G** an increase of  $1.6 \text{ m}^3$
  - H** an increase of  $2.4 \text{ m}^3$

- 12** Two numbers have a sum and product both equal to 10.  
What is the positive difference between the two numbers?
- A** 0
  - B**  $2\sqrt{5}$
  - C** 5
  - D**  $2\sqrt{15}$
  - E** 10
  - F**  $2\sqrt{35}$

- 13 Which one of the following statements about a kidney nephron in a healthy human is correct?
- A Blood plasma in a blood vessel leaving a glomerulus has more urea than the same blood plasma when it arrived in the glomerulus.
  - B Blood plasma in the glomerulus loses water by active transport into the lumen of the Bowman's capsule.
  - C Glucose from the nephron is absorbed by osmosis into the blood in the capillaries around the first coiled tubule.
  - D Red blood cells in the capillaries around the loop of Henle release oxygen which diffuses into the cells of the nephron.
  - E When ADH is released, less water is absorbed into the blood plasma from the urine in the collecting duct.
- 14 In an electrolysis of silver nitrate solution, sufficient electrons are passed into the solution to cause 0.010 mol of silver to be deposited at the negative electrode (cathode).

The same number of electrons is then passed into concentrated aqueous copper(II) chloride.

What are the maximum amounts of copper produced at the negative electrode and of chlorine gas produced at the positive electrode (anode)?

	<i>amount of copper at the negative electrode (cathode) / mol</i>	<i>amount of chlorine gas at the positive electrode (anode) / mol</i>
<b>A</b>	0.0050	0.0025
<b>B</b>	0.0050	0.0050
<b>C</b>	0.0050	0.010
<b>D</b>	0.020	0.010
<b>E</b>	0.020	0.020
<b>F</b>	0.020	0.040

- 15 The velocity–time graph is for a car of mass 1500 kg moving along a straight horizontal road.

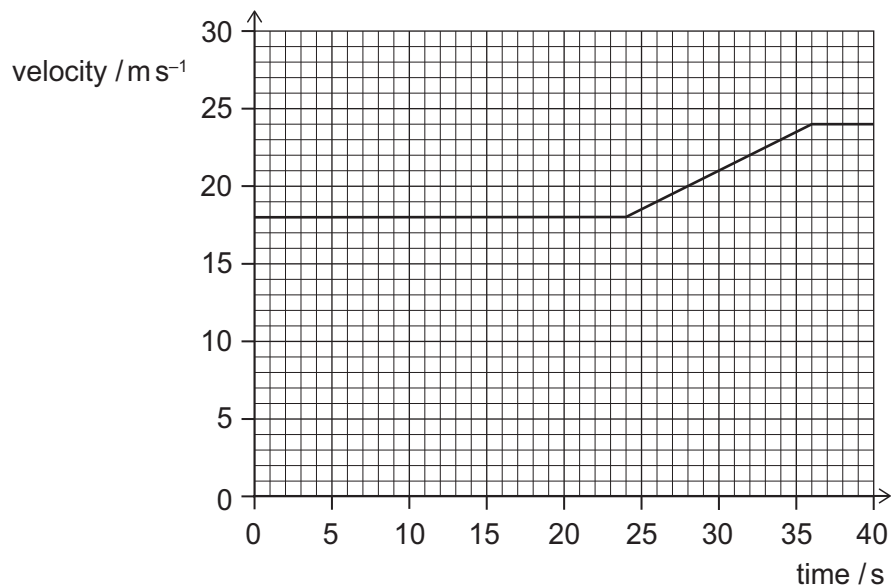

What is the magnitude of the resultant force on the car while it is accelerating?

- A 250 N
- B 750 N
- C 1000 N
- D 3000 N
- E 7500 N
- F 9000 N
- G 15000 N

**16** Straight line  $P$  has equation  $y = 3x + 7$

Straight line  $Q$  is parallel to  $P$  and intersects the  $y$ -axis at 2.

Straight line  $R$  is perpendicular to  $P$  and intersects  $P$  on the  $y$ -axis.

What is the  $x$ -coordinate of the point where  $R$  intersects  $Q$ ?

- A**  $\frac{5}{6}$
- B**  $1\frac{1}{2}$
- C**  $1\frac{5}{7}$
- D**  $1\frac{7}{8}$
- E**  $2\frac{7}{10}$

**17** Which of the following statements about bacterial plasmids is/are correct?

- 1** Plasmids carry the complete bacterial genome.
- 2** Plasmids contain genes that code for proteins.
- 3** Plasmids are essential for mitosis.

- A** none of them
- B** 1 only
- C** 2 only
- D** 3 only
- E** 1 and 2 only
- F** 1 and 3 only
- G** 2 and 3 only
- H** 1, 2 and 3

- 18 The equation for the reaction between aqueous copper(II) sulfate and excess aqueous rubidium iodide (RbI) is:

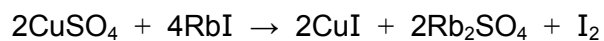

Which of the following statements about this reaction is/are correct?

- 1 Copper ions each lose one electron.
  - 2 The iodide ions are acting as a reducing agent.
  - 3 The rubidium ions are oxidised.
- A none of them
- B 1 only
- C 2 only
- D 3 only
- E 1 and 2 only
- F 1 and 3 only
- G 2 and 3 only
- H 1, 2 and 3

- 19** A train is travelling along a straight, horizontal section of track. The driver sees a maintenance worker ahead of the train on the track and so applies the brakes and the train decelerates. The driver also sounds a horn attached to the front of the train. The horn emits a note of constant pitch.

As the decelerating train approaches the worker, which of the following statements is/are correct?

- 1** The pitch of the note heard by the worker is decreasing.
  - 2** The period of the sound wave heard by the worker is less than the period of the sound wave heard by the driver.
  - 3** The sound wave approaches the worker at a speed that is decreasing.
- A** none of them
- B** 1 only
- C** 2 only
- D** 3 only
- E** 1 and 2 only
- F** 1 and 3 only
- G** 2 and 3 only
- H** 1, 2 and 3



20 Triangle  $PQR$  has an area of  $80 \text{ cm}^2$  and a right angle at  $P$ .

$S$  is a point on  $PR$  and  $T$  is a point on  $PQ$ .

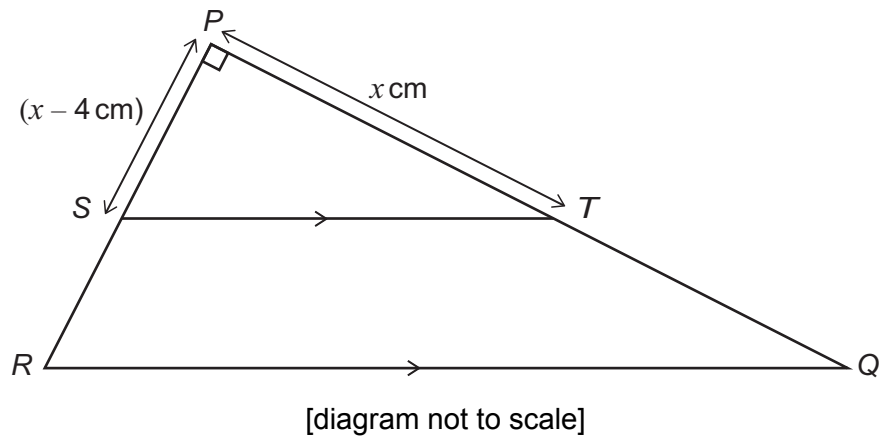

$ST$  is parallel to  $RQ$ .

$$RQ = 2ST$$

$$PT = x \text{ cm}$$

$$PS = (x - 4) \text{ cm}$$

What is the value of  $x$ ?

- A  $2\sqrt{6} - 2$
- B  $2\sqrt{6} + 2$
- C  $2\sqrt{11} - 2$
- D  $2\sqrt{11} + 2$
- E  $4\sqrt{6} - 4$
- F  $4\sqrt{6} + 4$
- G  $4\sqrt{11} - 4$
- H  $4\sqrt{11} + 4$

21 Most fungi are multicellular organisms.

Fungi can reproduce by either asexual or sexual reproduction.

The diagram shows one form of reproduction in fungi.

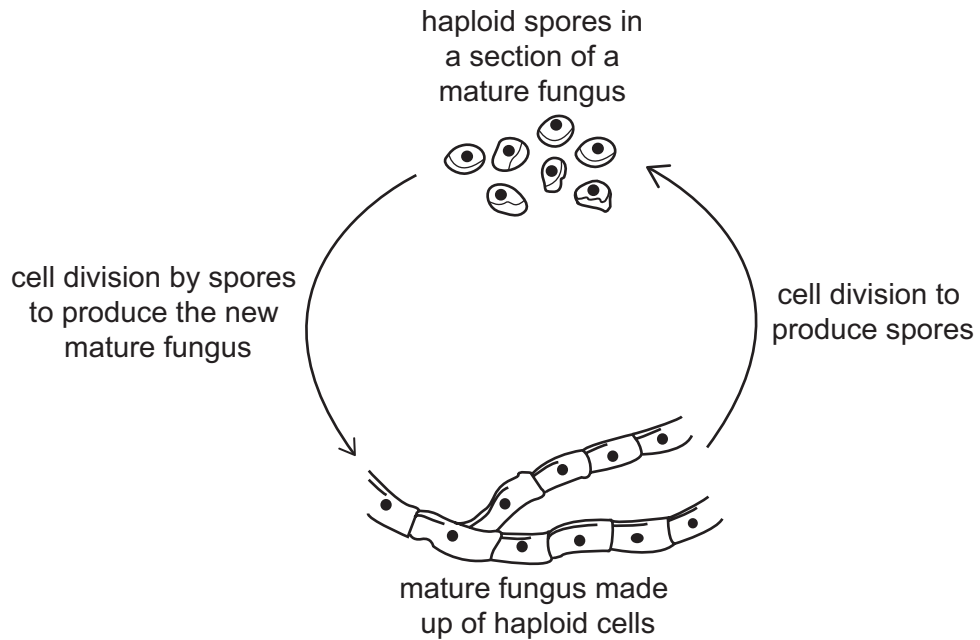

Which of the following rows correctly identifies the types of cell division that occur in this cycle, and the type of reproduction that is taking place?

	<i>cell division by spores to produce the new mature fungus</i>	<i>cell division to produce spores</i>	<i>type of reproduction</i>
<b>A</b>	meiosis	mitosis	asexual
<b>B</b>	meiosis	mitosis	sexual
<b>C</b>	meiosis	meiosis	asexual
<b>D</b>	meiosis	meiosis	sexual
<b>E</b>	mitosis	mitosis	asexual
<b>F</b>	mitosis	mitosis	sexual
<b>G</b>	mitosis	meiosis	asexual
<b>H</b>	mitosis	meiosis	sexual

- 22** In a calorimetry experiment, 100 g of water is heated from 20.0 °C to 30.0 °C by a methanol burner.

0.320 g of methanol fuel is completely combusted in this process.

How much heat would be transferred to water when 1.00 mol of methanol is burned in a similar experiment?

( $M_r$  value: methanol = 32.0. Assume that no heat is lost to the surroundings and that the specific heat capacity of water is  $4.20 \text{ J g}^{-1} \text{ °C}^{-1}$ .)

- A** 13.125 kJ
  - B** 13.440 kJ
  - C** 420.00 kJ
  - D** 1260.0 kJ
  - E** 1344.0 kJ
  - F** 4200.0 kJ
  - G** 13 125 kJ
- 23** A spring with spring constant  $k$  stores a certain amount of energy when it has a particular extension.

A second spring stores twice as much energy when its extension is half that of the first spring.

What is the spring constant of the second spring?

(The springs obey Hooke's law.)

- A**  $\frac{k}{8}$
- B**  $\frac{k}{4}$
- C**  $\frac{k}{2}$
- D**  $k$
- E**  $2k$
- F**  $4k$
- G**  $8k$

- 24 The diagram shows a shape consisting of half of a regular hexagon and half of a regular octagon, which have the line  $PS$  in common.

$P$ ,  $Q$ ,  $R$  and  $S$  are vertices of a regular hexagon with sides of length 4 cm.

$S$ ,  $T$ ,  $U$ ,  $V$  and  $P$  are vertices of a regular octagon.

$O$  is at the midpoint of  $PS$ .

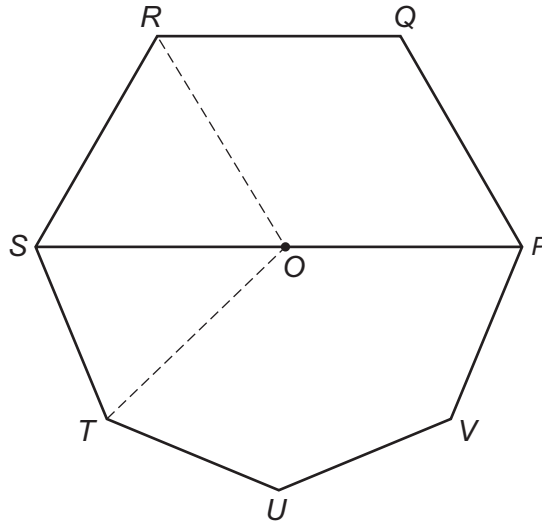

[diagram not to scale]

Calculate the ratio

area  $PQRS$  : area  $STUVP$

- A 1 : 1
- B  $1 : \frac{1}{3}\sqrt{3}$
- C  $1 : \frac{4}{9}\sqrt{3}$
- D  $1 : \frac{1}{3}\sqrt{6}$
- E  $1 : \frac{4}{9}\sqrt{6}$

- 25** In an experiment, plant tissue was placed in a solution containing known concentrations of glucose and sodium ions. The concentration of these substances in the tissue was then measured at regular time intervals.

The experiment was repeated with boiled plant tissue. Boiling the plant tissue kills the cells and destroys the cell surface membrane.

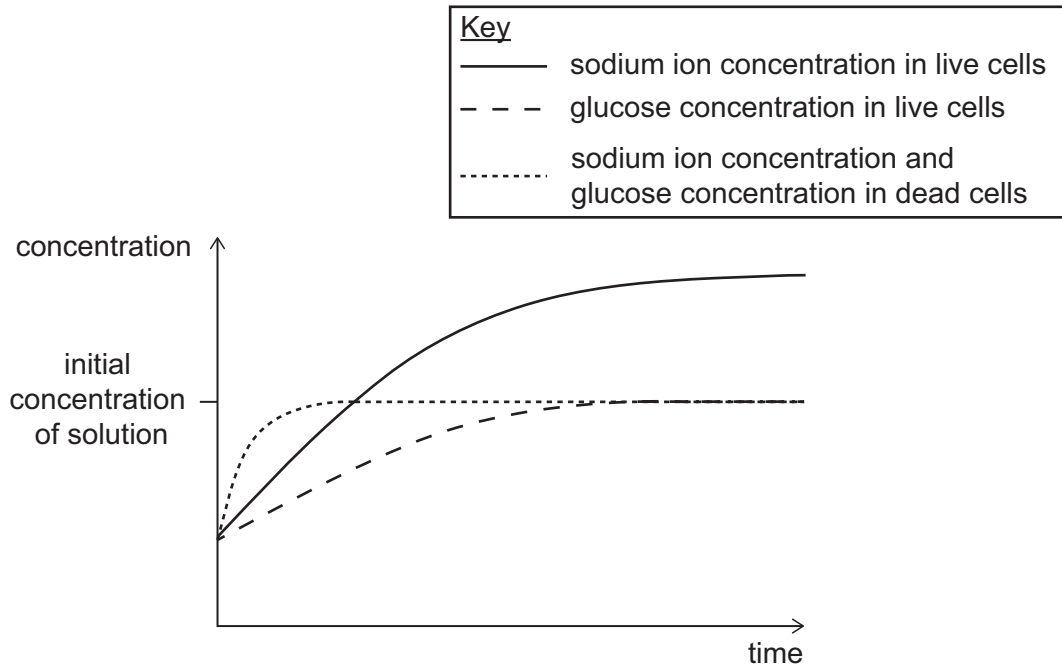

Which of the following statements about this experiment is/are correct?

- 1 The uptake of sodium ions can involve an active process in live cells.
  - 2 The uptake of sodium ions takes place by osmosis in dead cells.
  - 3 Diffusion is sufficient to explain the uptake of glucose in live and dead cells.
- A** none of them
- B** 1 only
- C** 2 only
- D** 3 only
- E** 1 and 2 only
- F** 1 and 3 only
- G** 2 and 3 only
- H** 1, 2 and 3

- 26** 4.00 g of calcium hydroxide was added to 200 cm<sup>3</sup> of water at room temperature. The mixture was stirred until no more solid dissolved. 3.63 g of calcium hydroxide was left undissolved.

What is the solubility, in mol dm<sup>-3</sup>, of calcium hydroxide at room temperature?

(A<sub>r</sub> values: Ca = 40; H = 1; O = 16)

- A** 1.850 mol dm<sup>-3</sup>
  - B** 0.245 mol dm<sup>-3</sup>
  - C** 0.032 mol dm<sup>-3</sup>
  - D** 0.025 mol dm<sup>-3</sup>
  - E** 0.005 mol dm<sup>-3</sup>
- 27** A 240 V ac supply is connected to the primary coil of an ideal transformer. There are 600 turns on this primary coil.

A resistor of resistance 10 Ω is connected to the secondary coil of the transformer. The resistor dissipates energy at a rate of 1440 W.

How many turns are on the secondary coil of the transformer?

- A** 30
- B** 100
- C** 300
- D** 1000
- E** 1200
- F** 3600

**END OF TEST**

**BLANK PAGE**

**BLANK PAGE**